



# Task Controller

# Functional Overview

(ISO11783 Part 10 & 11)

Hans Jürgen Nissen  
John Deere AMS Europe

20<sup>th</sup> February 2008

# Topics



- Introduction to Task Controller features
- Focus on Task Controller and Working Set, not Desktop interface and XML data structures
- Connection Management
- Process Data Message
- Process Data Trigger Methods
- Device Configuration Data structures

# Task Management



The main purpose of a Task Management is

- a. Management of farm resources
- b. Management of farm activities carried out mainly in the field

# Functionality covered by ISOBUS

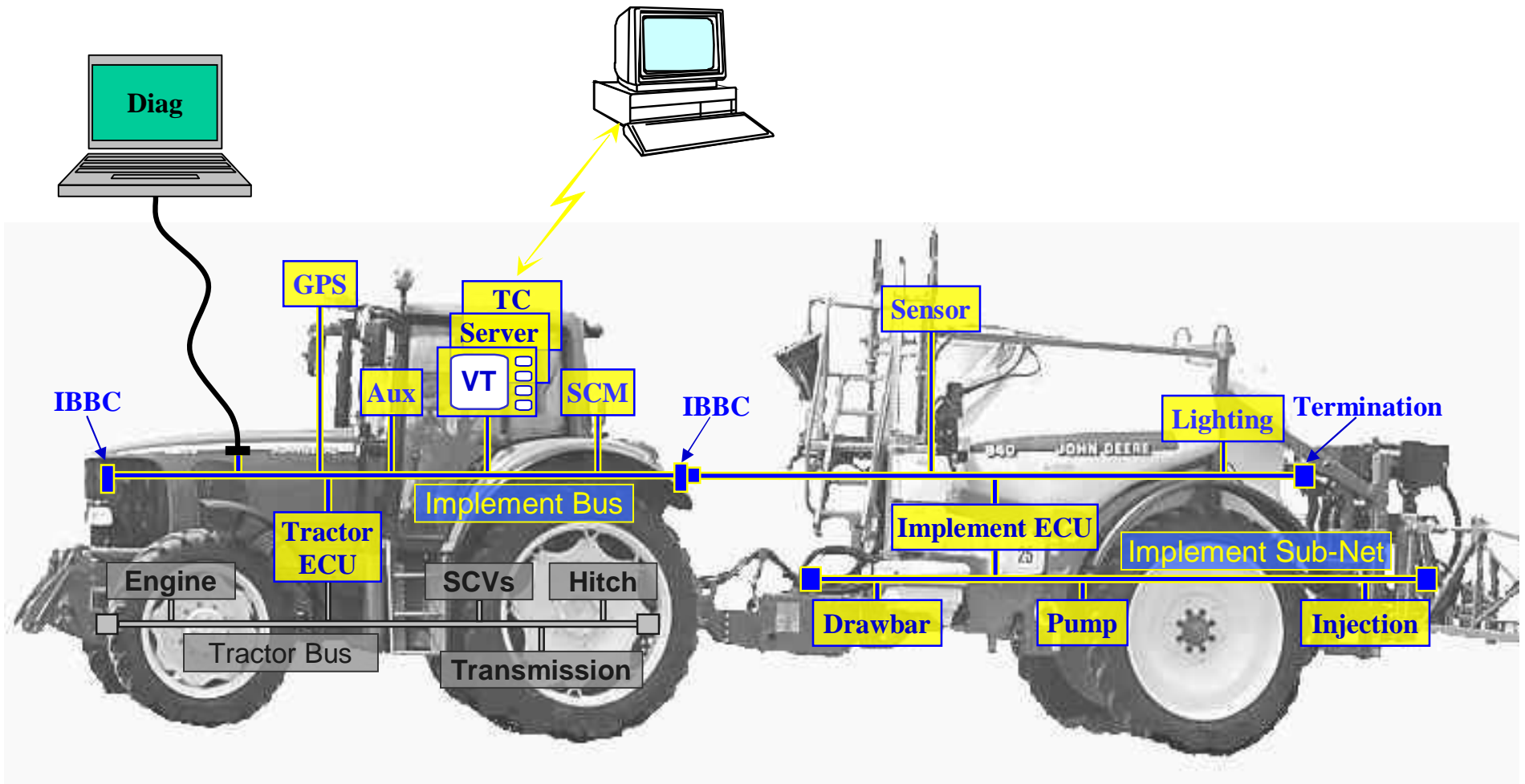

# ISO11783 – Documents

## - 14 Parts or Subdocuments -



• Part 1 (complete) – General Standard	• Part 8 (complete) – Drive Train
• Part 2 (complete) – Physical Layer	• Part 9 (complete) – Tractor ECU
• Part 3 (complete) – Data Link Layer	• <b>Part 10</b> (complete) – <b>Task Controller</b>
• Part 4 (complete) – Network Layer	• <b>Part 11</b> (complete) – <b>Mobile Ag Database</b>
• Part 5 (complete) – Network Management Layer	• Part 12 (complete) – Diagnostic Services
• Part 6 (complete) – Virtual Terminal	• Part 13 (complete) – File Server
• <b>Part 7</b> (complete) – <b>Implement Messages</b>	• Part 14 (draft) – Sequence Control

***The standard is a “work in progress”***

# Functionality covered by ISOBUS

## - Task Controller (TC) -



- Standardized Interface between the Mobile System and the Farm Management Information System (PC in farm office)
- Standardized file format (XML based) between TC and FMS
- Standardized communication between Task Controller (TC) and controllers on the bus (Process Data Message = PDM)
- Documentation of work of the mobile system (totals of tractor, implements, time stamps, etc.; geo-referenced when GPS available)
- Prescription for multiple implements in parallel
- Handling of Coding Data (all kinds of setup data like operator names, farm and field names, machine information, etc)
- Handling of Machine Configuration (mounting positions including their position offsets, working width, etc)
- Data Dictionary (ISO11783 part 11) defines the data types (realized as online-dB on [www.isobus.net](http://www.isobus.net))

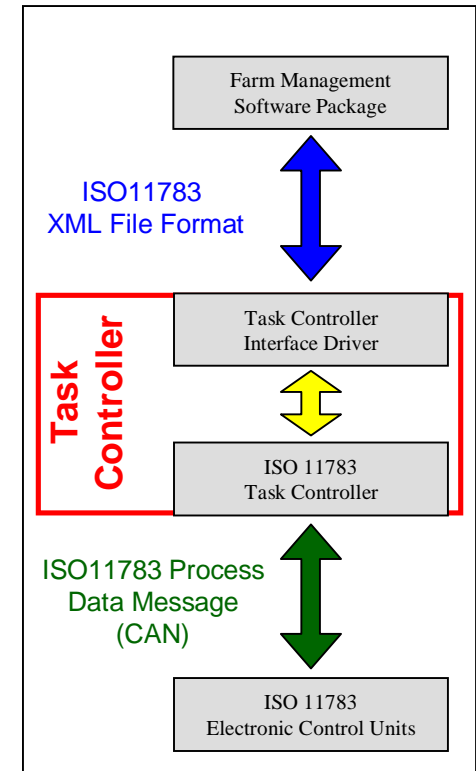

# Functionality covered by ISOBUS

## - Task Controller (TC) -

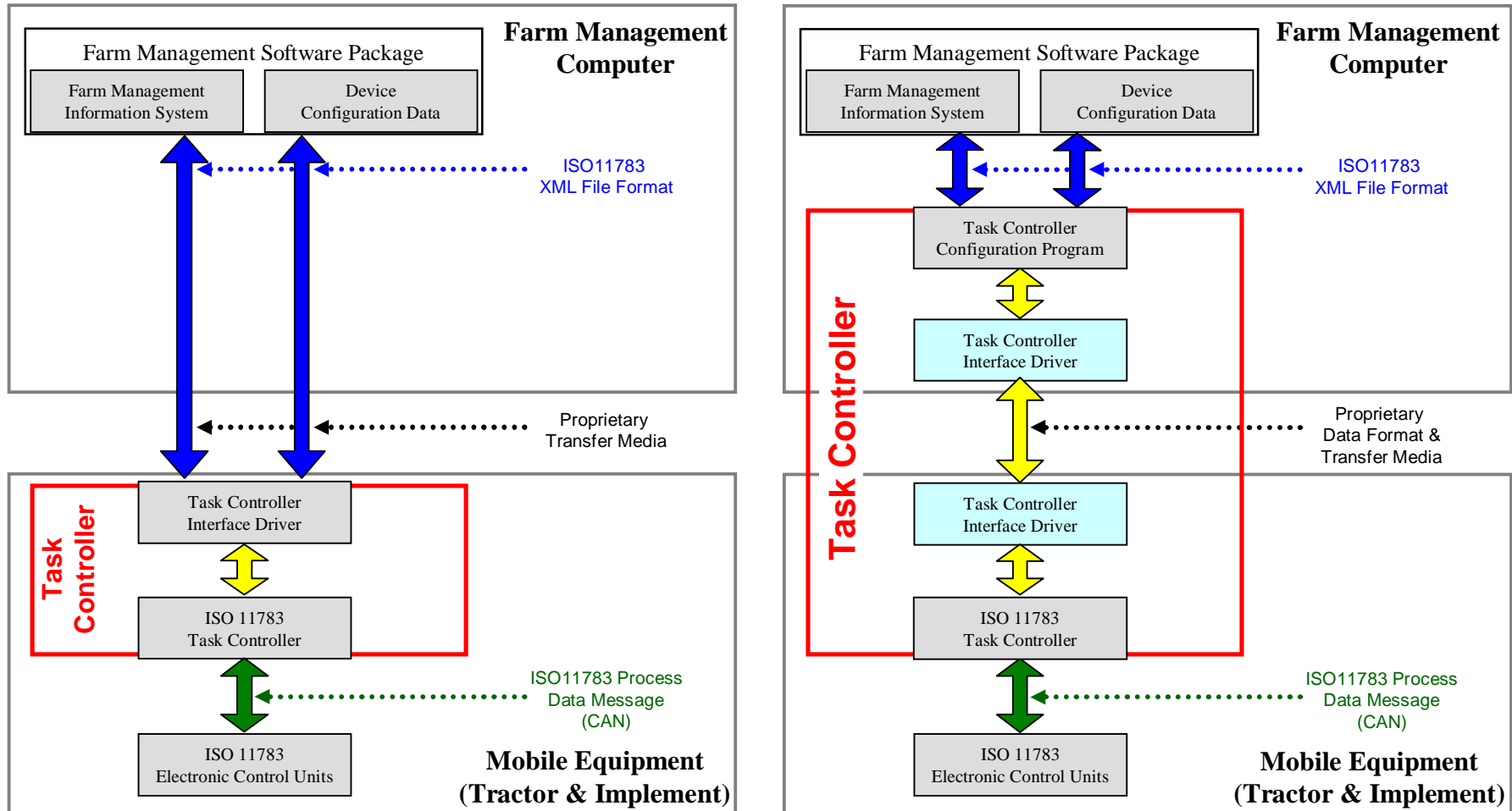

### Legend:

- Standardized Data Exchange via ISO11783 XML-based Data Transmission File
- Not Standardized Data Exchange via proprietary File formats and Transfer Media
- Standardized Data Exchange on CAN bus via ISO11783 Process Data Message (PDM)

# Task Management



## Foreseen Workflow:

- a. Planning of field Task on the desktop computer  
(Farm Management Information System = FMIS)  
What, Where, How, by Whom, When, etc.
- b. Conversion of task into standard XML format
- c. Assignment of task data to “implements”  
(Working Sets clearly identified by their NAME)
- d. Transfer from PC to Mobile TC (this may includes a conversion)
- e. TC transmits information as specified to “implement” controllers
- f. TC collects information as specified in the field  
Totals, site specific data Logging, new Coding Data, etc
- g. Transfer of data back to PC (this may includes conversion)
- h. Analyzing of field data in FMIS

# Task Controller User-Interface



A User-Interface is not mandatory, nevertheless common & useful to

- a. Select a task from a list
- b. Start/Stop a task
- c. Modify a task
- d. Create a task
- e. Add new Coding Data
- f. Display Warnings as needed
- g. Provide Total Overviews
- h. etc

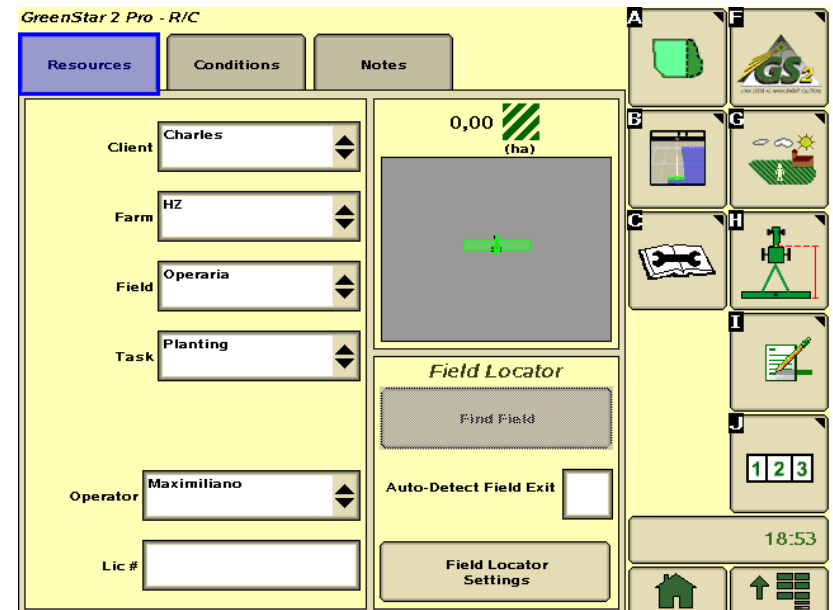

# Connection Management



For seamless and proper functionality in the field special attention needs to be paid to the connection Management!

The Task Controller shall on Startup:

- a. Complete its correct Address Claim
- b. Wait for 6 seconds after complete Address Claim
- c. Start transmission of cyclic TC Status Message (initial status is '0')
- d. Allow WS to initialize and load their Device Configuration Data (DCD)
- e. Parse the DCD on activation message and respond accordingly
- f. Set the TC Status to '1' when all needed settings are valid (task chosen and activated, all included WS connected, etc)

# Connection Management



The Working Set shall on Startup:

- a. Complete its correct Address Claim
- b. Wait for 6 seconds after complete Address Claim
- c. Wait for TC Status Message
- d. Identify itself and its members to the system
- e. Start transmission of frequent WS Task Status Message
- f. Query TC as to determine its capabilities
- g. Request Language format
- h. Query TC if DCD already exists (version etc)
- i. Load DCD when not available or existing one doesn't reflect the machine settings
- j. Wait for TC feedback on DCD Activation Message

# Data Logging



- The WS define in their DCD which elements can provide information for data logging
- The Desktop SW usually defines which data to log for a certain operation (transferred in the XML task file as DataLogTriggers to the TC)
- DataLogTriggers allow to
  - log a certain DDI from a certain DCD element of a specific WS
  - log specific Bits/Bytes from certain PGNs on the bus
  - log these data on certain intervals or thresholds (Trigger methods)
  - log cumulative total counters
- Data can come in on different rates; special rules apply how the data gets logged in the binary data files send back to the PC.
- Data is usually log with GPS position and time stamps
- A Process Data Value can be send with a maximum of 10 times per second.

# Data Logging



System behavior on Start, Pause and Resume of a Task:

Start:

- The TC sets the Task Status in its Status Message to '1'.
- The WS sets all Total Counters to zero on the transition from '0' to '1'.
- The TC enables the Trigger Methods for the individual Process Data Variables as appropriate.

Pause:

- The TC sets the Task Status in its Status message to '0'.
- The WS stops increasing its total counters.
- The WS stops sending its triggered data.
- The TC requests from each WS each individual information marked as 'counter' in its DCD and stores them in the task file.

Resume:

- Same as 'Start', but
- TC restores the previously stored total counters in each WS

# Site-specific Application



- TC and WS may support prescriptions (WS defines e.g. its application rate as 'set-able' in its DCD)
- Application map gets planed at Desktop PC
- Application map gets attached to XML Task file as Grid or Shape File
- TC opens application map in the field
- TC determines the appropriate application rate based on GPS position in the application map
- TC may takes offset of GPS to drop point into account (e.g. distance between GPS and Sprayer Boom)
- TC sends the new application rate to the correct object of the connected WS
- WS applies the new application rate when appropriate (e.g. Manual versus Auto Mode)
- WS sends new current rate for documentation purpose



# Process Data Message (PDM)



## Technical Data Message (cont'd):

### Layout of Data Bytes

Command	Sub Com	Command Specific Parameters
4 bits	4 bits	56 bits
Byte 1		Byte 2 - 8

Request DCD Localization Label (WS to TC)	0001	0010	= 0xFF
Response DCD Localization Label (TC to WS)	0001	0011	7 char DCD Localization Label
Request DCD Pool transfer (WS to TC)	0001	0100	Byte 2-5 = DCD size in Byte Byte 6-8 = 0xFF
Response DCD Pool transfer (TC to WS)	0001	0101	Byte 2 = Memory Status Byte 3-8 = 0xFF
DCD Pool transfer (WS to TC)	0001	0110	Byte 2-n = DCD Objects **
DCD Pool transfer Response (TC to WS)	0001	0111	Byte 2 = error code Byte 3-6 = Bytes received Byte 7-8 = 0xFF

\*\* Requires TP or ETP

# Process Data Message (PDM)



## Technical Data Message (cont'd):

### Layout of Data Bytes

Command	Sub Com	Command Specific Parameters
4 bits	4 bits	56 bits
Byte 1		Byte 2 - 8

DCD activation (WS to TC)	0001	1000	Byte 2-8 = 0xFF
DCD activation Response (TC to WS)	0001	1001	Byte 2 = error code Byte 3-8 = further info on error
DCD Pool Delete message (WS to TC)	0001	0100	Byte 2-8 = 0xFF
DCD Pool Delete response (TC to WS)	0001	1011	Byte 2 = error code Byte 3-8 = 0xFF
Change Designator message (WS to TC)	0001	1100	Byte 2-3 = Object ID Byte 4 = Number of Chars Byte 5-n = Designator **
DCD Pool transfer Response (TC to WS)	0001	1101	Byte 2-3 = Object ID Byte 4 = error code Byte 5-8 = 0xFF

\*\* Requires TP or ETP

# Process Data Message (PDM)



## Process Variable Handling:

### Layout of Data Bytes

Com	Element #	DDI		Process Variable Value			
4 bits	12 bits	16 bits		32 bits			
Byte 1	Byte 2	Byte 3	Byte 4	Byte 5	Byte 6	Byte 7	Byte 8

### Command

Defines the action to be taken

### Element Number

Defines the addressed Object in the DCD

Reason: not enough space in the PDM for the complete Object ID

### Data Dictionary Identifier (DDI)

Specifies the accessed parameter of the DCD Element

Details defined in Part 11 (online dB)

### Process Variable Value

Contains the actual data of the PDM

The definition depends on the Command.

# Process Data Message (PDM)



## Process Variable Handling (cont'd):

Command	Meaning
0x00 & 0x01	<b>Technical Data Message</b>
0x02	<b>Manual Value Request (TC to WS)</b>
0x03	<b>Value Command</b> a) actual value send from WS to TC (e.g. response to Manual Value Request) b) TC to WS in case of prescription for instance
0x04	<b>Time based Measurement Command (TC to WS)</b> The Process Variable Data defines the time interval.
0x05	<b>Distance based Measurement Command (TC to WS)</b> The Process Variable Data defines the distance interval.
0x06	<b>Minimum Threshold Measurement Command (TC to WS)</b> The Process Variable Data defines the minimum value the object needs to have before the element gets send.
0x07	<b>Maximum Threshold Measurement Command (TC to WS)</b> The Process Variable Data defines the maximum value up to the element gets send

# Process Data Message (PDM)



## Process Variable Handling (cont'd):

Command	Meaning
0x08	<b>On-Change Threshold (TC to WS)</b> The WS sends the process data value only when the change since last transmission is larger than the threshold.
0x09 - 0x0C	Reserved
0x0D	<b>Negative Acknowledgement (NACK)</b> Send when the command got rejected for reason included in Process Data value.
0x0E	<b>Task Controller Status (TC to global)</b> Cyclic status message send every 2 seconds after completion of start-up sequence. The WS Master time out of the connection after this message fails for 6 seconds. Includes the Task Status in the Process Data value field, which triggers the overall system.
0x0F	<b>Working Set Task Status (WS to TC)</b> Each individual WS indicates its availability by sending this message at a 2 second interval. The TC times out the connection after this message fails for 6 seconds. The task status gets reflected in the Process Data value field.

# Process Data Trigger Methods

- o Supported Trigger Methods are defined per Process Data Variable in the DCD
- o Based on Triggers the values are only send while the Task Status is '1'
- o The manual request of values works at any time (independent of Task Status)
- o The TC can define individual limitations for the Triggers activated for a particular Process Data Value.

## Combination of Trigger Methods:

- o 'Time interval', 'distance interval' and 'on-Change' can be used in any combination, while any of the three triggers occurring first resets all three trigger counters for that value.
- o All three trigger methods can be combined with the 'Min-' and 'Max-Threshold', while the value is only send when it stays within the Threshold limitations.
- o If the 'Min-Threshold' limitation is smaller than the 'Max-Threshold' limitation, then the logging is active while the value is in-between the two limitations.



- o If the 'Min-Threshold' limitation is larger than the 'Max-Threshold' limitation, then the logging is active while the value is below the 'Max-Threshold' or above the 'Min-Threshold'.



See Part 10 Annex D – DataLogTrigger (DLT) for more details!

# Process Data Trigger Methods



What does this mean for the design of a TC-module in a Working Set?

The WS TC-module needs to

- o know which Device Process Data Objects (DPD) are available per DCD Element
  - to filter incoming trigger commands etc
  - to forward incoming value changes to correct Element in the application
- o know which triggers are supported for each individual DPD
  - to filter incoming trigger commands
- o know which triggers are set per DPD
  - to enable the internal trigger handling accordingly
- o know which limits are defined for individual triggers and DPD
  - to feed the internal trigger handling accordingly
- o handle individual variables per trigger and DPD (e.g. Thresholds, etc) to ensure independent handling
- o apply the rules for combinations of trigger methods per DPD etc
- o store the 'current value' (actual rate) independent of the 'commanded value' (e.g. prescription rate)
  - to allow the application to decide when it applies a new 'commanded value' to its operation (Manual versus Automatic mode)
  - to report the actually used value to the TC while the last commanded value didn't get applied yet

# Device Configuration Data (DCD)



- o Also referred to as Device Description Data (DDD)
- o The DCD describes the connected Working Set for the TC and Desktop SW
  - Number of bins (tanks), booms, sections
  - the structural relationship between the objects (sections are children to a boom, etc)
  - the offsets of the objects to each other (x-, y-, z-offset)
  - which Process Data Variables a particular DCD element supports (e.g. boom supports on/off status and current application rate)
  - version, embedded language and unit settings (localization label)
- o A valid DCD has to be available per Working Set for a standard TC communication
  - either as runtime upload via CAN at system start-up
  - or offline via import into Desktop SW

# Device Configuration Data (DCD)



The Object Hierarchy:

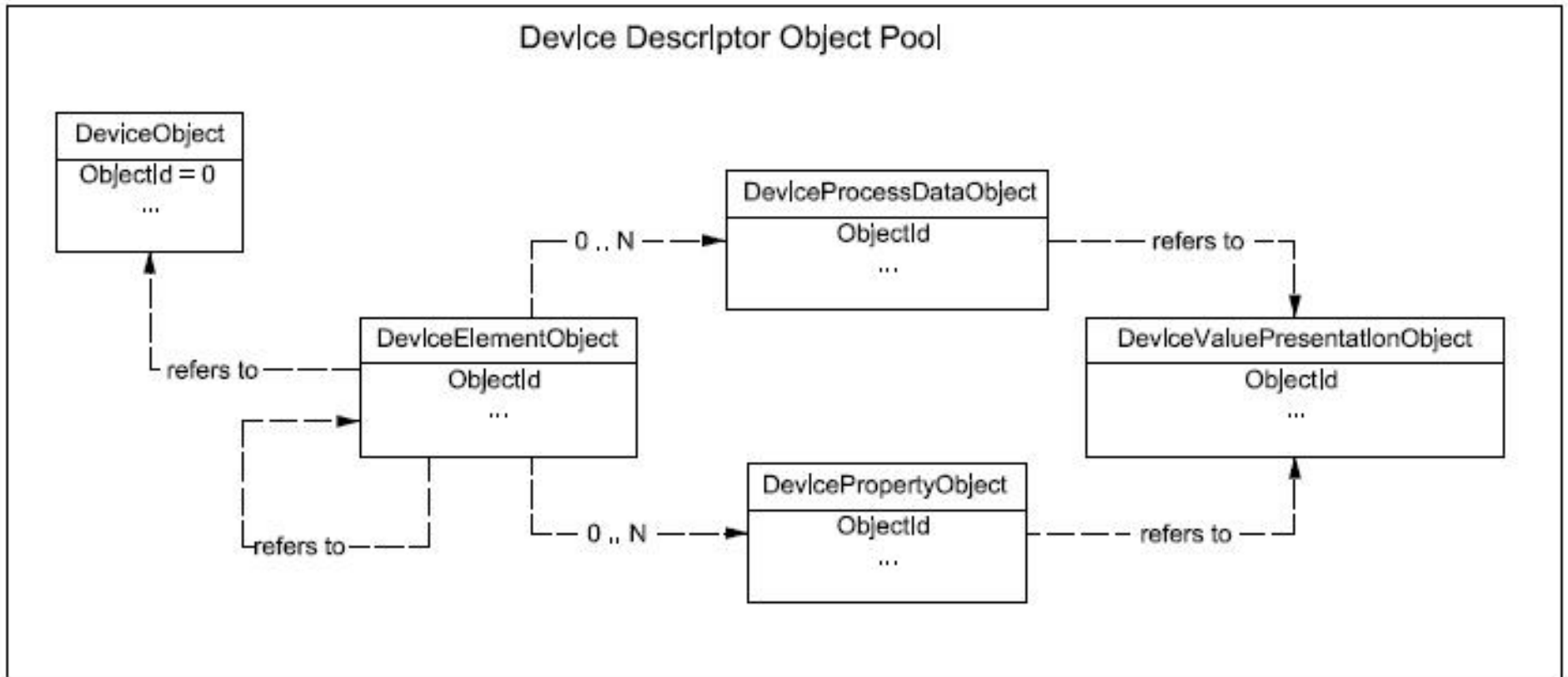

# Device Configuration Data (DCD)



## Device Element Object (DET):

- o Multiple objects of type DET represent the machine functions
- o Object Fields:
  - o Object ID
  - o Object Designator (string may be displayed by the TC)
  - o Device Element Types
    - o Device – represents the overall machine (e.g. sprayer)
    - o Function – generic object to represent sensors, booms, etc
    - o Bin – Sprayer tanks or planter bins, etc
    - o Section – represents individual row units for planters, sprayers, etc
    - o Unit – Sub-units of Sections (e.g. nozzles of a sprayer section)
    - o Connector – Connection point between different WS  
(e.g. at the back of the tractor and at the front of the drawbar)
    - o Nav. Ref. Point – Mounting location for GPS receivers etc
  - o Device Element Number  
individual number used to identify this object in the PDM
  - o Parent Device Element ID (section objects point to their boom etc)
  - o List Object IDs of Child Objects
- o Each DCD has to have one DET object of type Device representing the machine

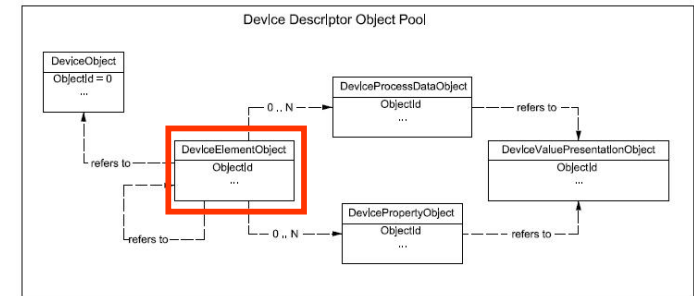

# Device Configuration Data (DCD)



## Device Object (DVC):

- o Each DCD has to have one DVC object
- o Represents the overall DCD
- o Object Fields:
  - o Object ID
  - o Object Designator (string may be displayed by the TC)
  - o Software Version of the related application
  - o NAME of owning WS Master
  - o Serial Number of WS Master
  - o Structure Label
    - Proprietary information about the machine configuration represented by the DCD
  - o Localization Label
    - Unit and Language settings represented by the DCD

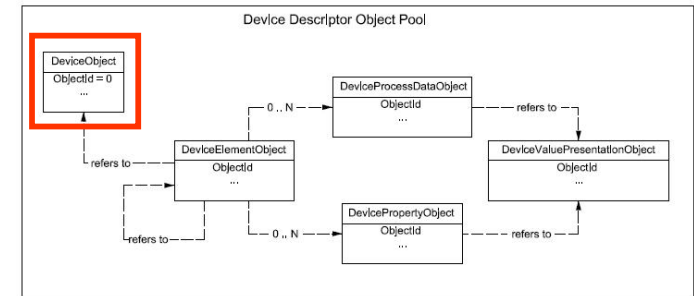

# Device Configuration Data (DCD)



## Device Process Data Object (DPD):

- o DPD objects represent the values (DDI) supported by the parent object for recording etc, e.g.
  - current application rate
  - application rate set-point (for prescription)
  - on/of status
- o Object Fields:
  - o Object ID
  - o Object Designator (string may be displayed by the TC)
  - o Process Data Element ID (DDI as specified in part 11 dB)
  - o Process Data properties
    - DDI is set-able => the TC can prescribe this value
    - DDI is part of 'Default Data Set' of this WS
  - o Supported Trigger Methods
    - time and distance interval
    - min and max threshold limits
    - on-change
    - total counter
  - o Reference to Device Value Presentation Object (Object ID)

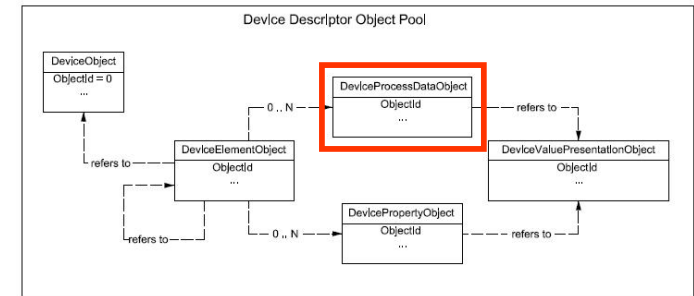

# Device Configuration Data (DCD)



## Device Property Object (DPT):

- o DPT objects represent fixed values which don't change during operation; e.g.

- x-, y-, z-offsets
- bin-size

- o Object Fields:

- o Object ID
- o Object Designator (string may be displayed by the TC)
- o Process Data Element ID (DDI as specified in part 11 dB)
- o Property Value (actual fixed value of this DDE)
- o Reference to Device Value Presentation Object (Object ID)

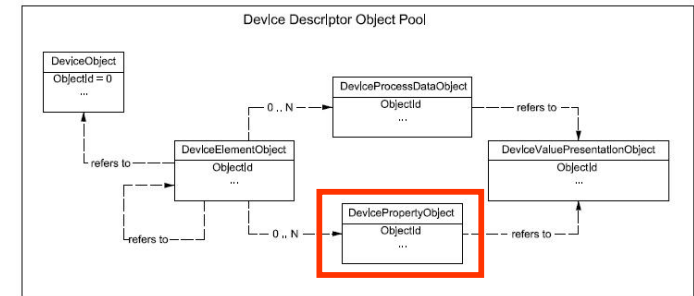

# Device Configuration Data (DCD)



## Device Value Presentation Object (DVP):

- o DVP objects define how the value of the parent object may be displayed to the operator in terms of units, value scaling, etc
- o Object Fields:
  - o Object ID
  - o Object Designator (string may be displayed by the TC)
  - o Offset to be applied before displaying the value
  - o Scale to be applied before displaying the value
  - o Number of Decimals (number of digits behind decimal point)
  - o Unit Designator String

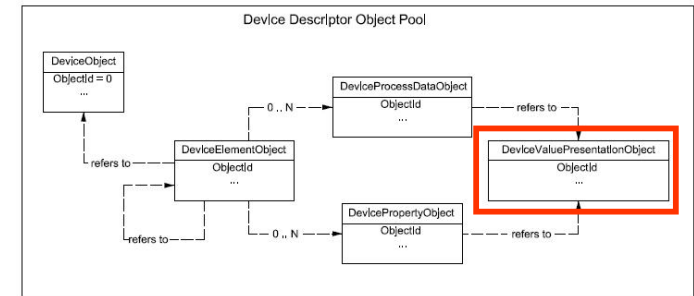

# Device Configuration Data (DCD)



## Task Controller Device geometry definitions

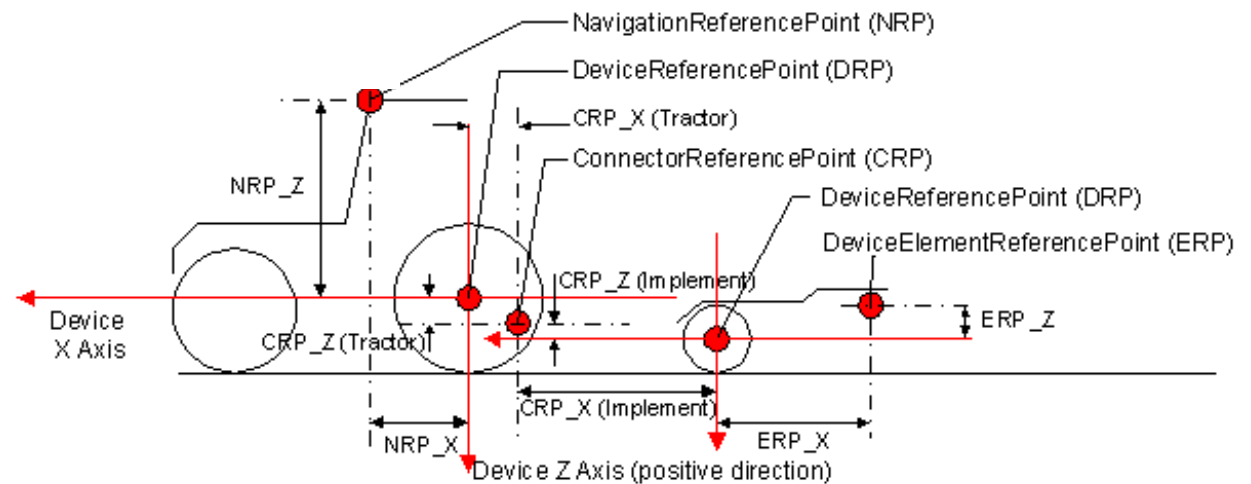
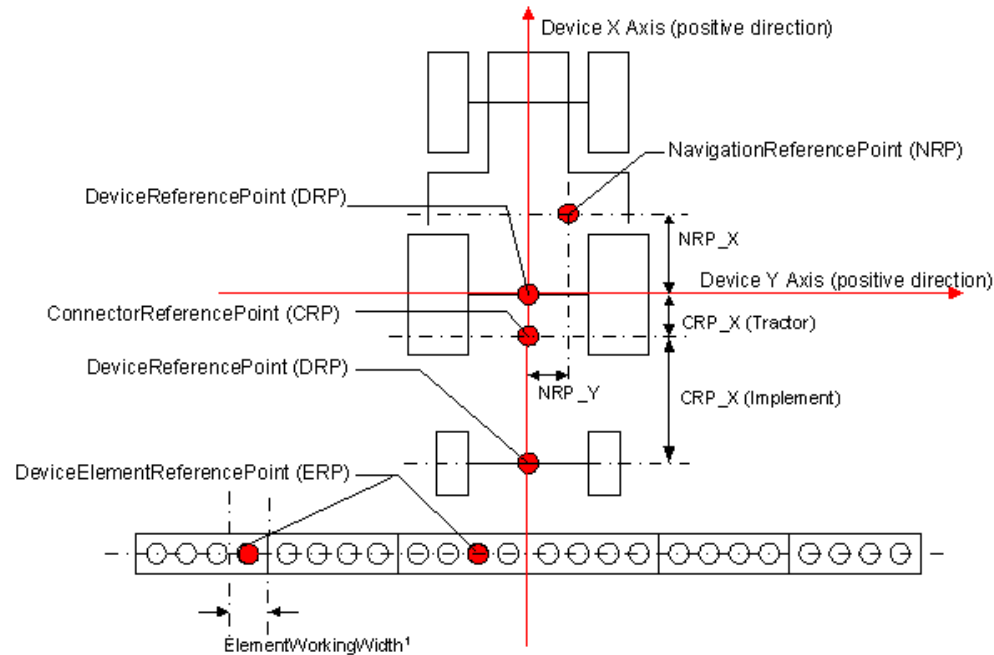

# Device Configuration Data (DCD)



The Object reference Coordinate System:

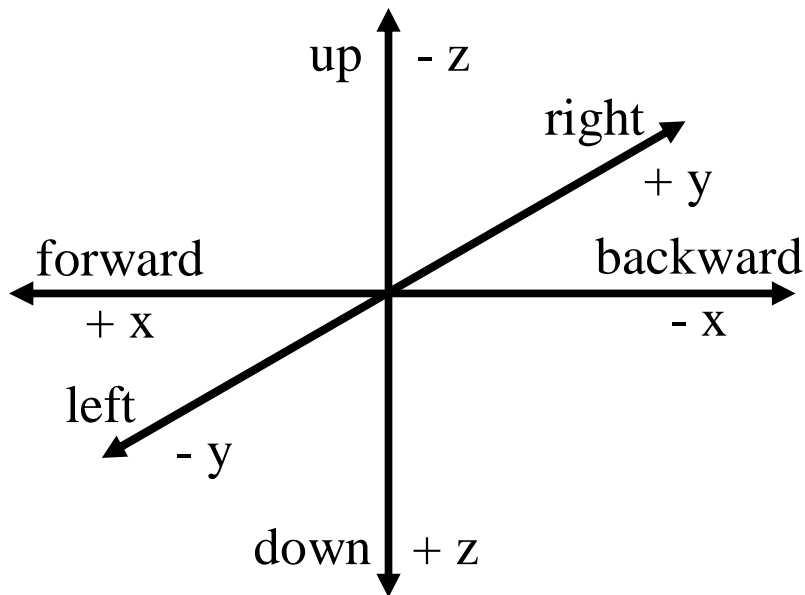

x-axis is specified as positive in normal driving direction

y-axis is specified as positive to the right of the normal driving direction

z-axis is specified as positive downward towards the ground

# Data Dictionary Element (DDE)



## What information contains the DDE?

o DDE's are defined in the online dB of part 11 (see [www.isobus.net](http://www.isobus.net))

o A DDE includes the following information

- o Unique Identifier (DDI)
- o Clear definition
- o Unit definition
- o Value Range
- o Resolution
- o Diagnostic information (SPN)
- o Comments
- o Device Class supported by the DDE

ID	<b>6</b> - Set-point Mass per Area Application Rate
Definition	Set-point Application Rate specified as mass per Area
Units	mg / m <sup>2</sup>
Range	0 - 2 147 483 647 mg / m <sup>2</sup> 0 - 2.147 t / m <sup>2</sup> 0 - 439.84 lb / foot <sup>2</sup>
Resolution	1.0 / bit
SAE SPN	not specified
Comments	none
Device Class	4 - Planter 5 - Fertilizer 6 - Sprayer

o dB allows to download all DDE's defined into an Excel Spreadsheet

o Requests for new DDE's are evaluated and assigned by an international Expert Team

# Part 11 – online dB



Search records - Microsoft Internet Explorer

Datei Bearbeiten Ansicht Favoriten Extras ?

## ISOBUS Data Dictionary

[<< Back](#) [Home](#)

**Search criteria**

DD Identifier  
 Device Class  
 Units  
 Definition

1 - Setpoint Volume Per Area Application Rate

1 - Tractor

Units  
 Definition

Search

**Search results:**

The following table contains all entities matching the search criteria. For a detailed view select one or more entities and click "Show details".

<input checked="" type="checkbox"/>	<b>53 - Default Tillage Depth</b>
Definition	Default Tillage Depth below soil surface, value increases with depth
Units	mm
Device Class(es)	1 - Tractor 2 - Primary Soil Tillage 3 - Secondary Soil Tillage 4 - Planters /Seeders 5 - Fertilizer 8 - Root Harvester
<input checked="" type="checkbox"/>	<b>117 - Effective Total Distance</b>
Definition	Accumulated Distance in working position

Start | Gerh... | 3 Mi... | 4 W... | 5 A... | 2 Mi... | 5 In... | 2 Mi... | DE | 100% | 12:33

# DCD Example

- o Sprayer with 9 Sections
- o Each Section provides
  - o its on/off status
  - o its working width
  - o Y-offset (left to right)
- o The Boom provides
  - o Target Rate (set-able)
  - o Application Rate
  - o Master Valve on/off status
  - o Total Volume applied
  - o Total Area sprayed
  - o Total Distance Driven
  - o Total Time
  - o its x-offset (in driving direction)
- o Several additional information like Device Value Presentation objects per offset etc are missing

```
DVC_840SE_SPRAYER
├─ DET_BOOM27_15_9X3
│   ├── DPD_TARGETRATE
│   ├── DPD_APPLIEDRATE
│   ├── DPD_MASTERONOFF
│   ├── DPD_TOTALAPPLIEDVOLUME
│   ├── DPD_TOTALSPRAYEDAREA
│   ├── DPD_TOTALSPRAYEDDISTANCE
│   ├── DPD_TOTALSPRAYEDTIME
│   └── DPT_XOFFSETBOOM
├─ DET_SEC_R4
│   ├── DPD_SEC_ONOFF
│   ├── DPT_SEC_WIDTHR4
│   └── DPT_YOFFSETR4
├─ DET_SEC_R3
│   ├── DPD_SEC_ONOFF
│   ├── DPT_SEC_WIDTHR3
│   └── DPT_YOFFSETR3
├─ DET_SEC_R2
│   ├── DPD_SEC_ONOFF
│   ├── DPT_SEC_WIDTHR2
│   └── DPT_YOFFSETR2
├─ DET_SEC_R1
│   ├── DPD_SEC_ONOFF
│   ├── DPT_SEC_WIDTHR1
│   └── DPT_YOFFSETR1
├─ DET_SEC_C
│   ├── DPD_SEC_ONOFF
│   ├── DPT_SEC_WIDTHC
│   └── DPT_YOFFSETC
├─ DET_SEC_L1
│   ├── DPD_SEC_ONOFF
│   ├── DPT_SEC_WIDTHL1
│   └── DPT_YOFFSETL1
├─ DET_SEC_L2
│   ├── DPD_SEC_ONOFF
│   ├── DPT_SEC_WIDTHL2
│   └── DPT_YOFFSETL2
├─ DET_SEC_L3
│   ├── DPD_SEC_ONOFF
│   ├── DPT_SEC_WIDTHL3
│   └── DPT_YOFFSETL3
└─ DET_SEC_L4
    ├── DPD_SEC_ONOFF
    ├── DPT_SEC_WIDTHL4
    └── DPT_YOFFSETL4
```



# Task Controller

# Functional Overview

(ISO11783 Part 10 & 11)

Hans Jürgen Nissen  
John Deere AMS Europe